

| REVISIONS |                             |           |          |
|-----------|-----------------------------|-----------|----------|
| LEVEL     | DESCRIPTION                 | APPROVED  | DATE     |
| 1         | REVISED WITH CURRENT MODELS | M SCHRAPP | 10/17/14 |

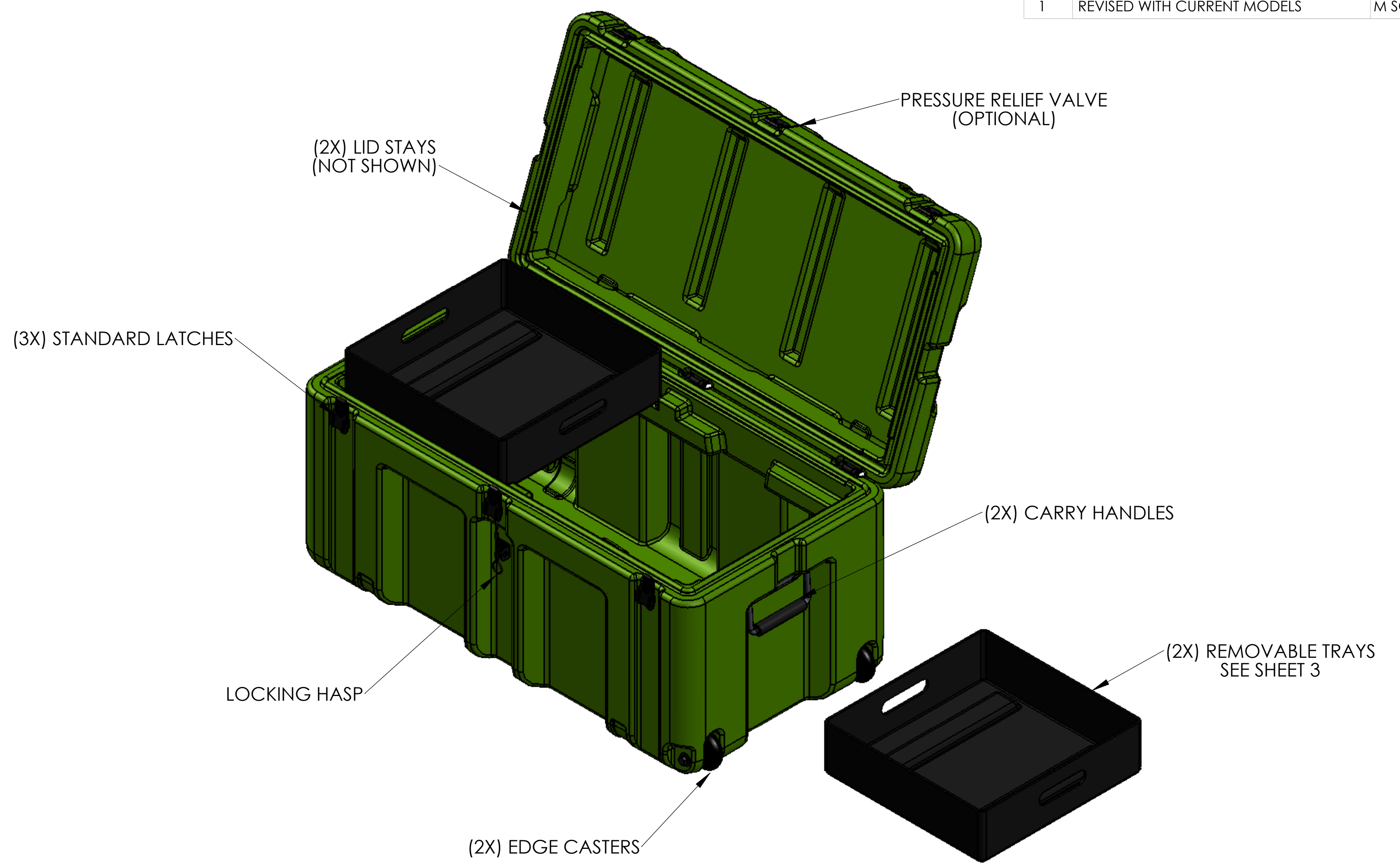

|   |   |                             |
|---|---|-----------------------------|
| MATERIALS:  | DIMENSIONAL TOLERANCES                          |                             |
| MEDIUM DENSITY ROTATIONALLY MOLDED POLYETHYLENE             | ALL DIMENSIONS IN INCHES UNLESS NOTED OTHERWISE |                             |
|   | 00 - 06"  | 0.020 + 0.005 * (DIMENSION) |
|   | 06 - 50"  | 0.030 + 0.005 * (DIMENSION) |
|   | 50 - 100"                                       | 0.030 + 0.006 * (DIMENSION) |
| ONE COMPLETE SET INCLUDES:                                  | ASSEMBLY:                                       |                             |
| ONE (1) CASE, AS SHOWN<br>TWO (2) REMOVABLE TRAYS, AS SHOWN | XXXX  |                             |

|          | NAME      | DATE     |
|----------|-----------|----------|
| DRAWN    | M SCHRAPP | 02/28/11 |
| CHECKED  | J THOMSON |          |
| APPROVED | J THOMSON |          |

  
**AMERIPACK**

TITLE:  
AMERIPACK  
AP3013-1303WH  
MILITARY FOOTLOCKER

SIZE | DWG. NO. | REV  
**C** AP3013-1303WH | 1

SCALE: N/A | SHEET 1 OF 3

**PROPRIETARY AND CONFIDENTIAL**  
THE INFORMATION CONTAINED IN THIS DRAWING IS THE SOLE PROPERTY OF AMERIPACK. ANY REPRODUCTION IN PART OR AS A WHOLE WITHOUT THE WRITTEN PERMISSION OF AMERIPACK IS PROHIBITED.

8 7 6 5 4 3 2 1

F

E

D

C

B

A

**PROPRIETARY AND CONFIDENTIAL**  
 THE INFORMATION CONTAINED IN THIS DRAWING IS THE SOLE PROPERTY OF AMERIPACK. ANY REPRODUCTION IN PART OR AS A WHOLE WITHOUT THE WRITTEN PERMISSION OF AMERIPACK IS PROHIBITED.

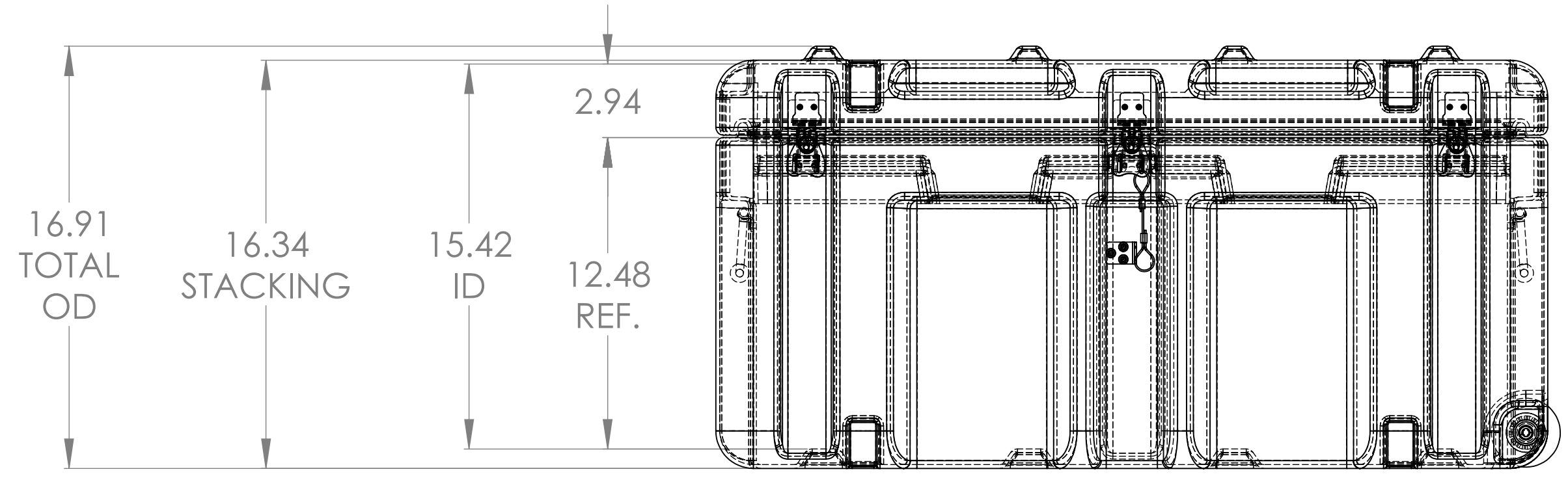
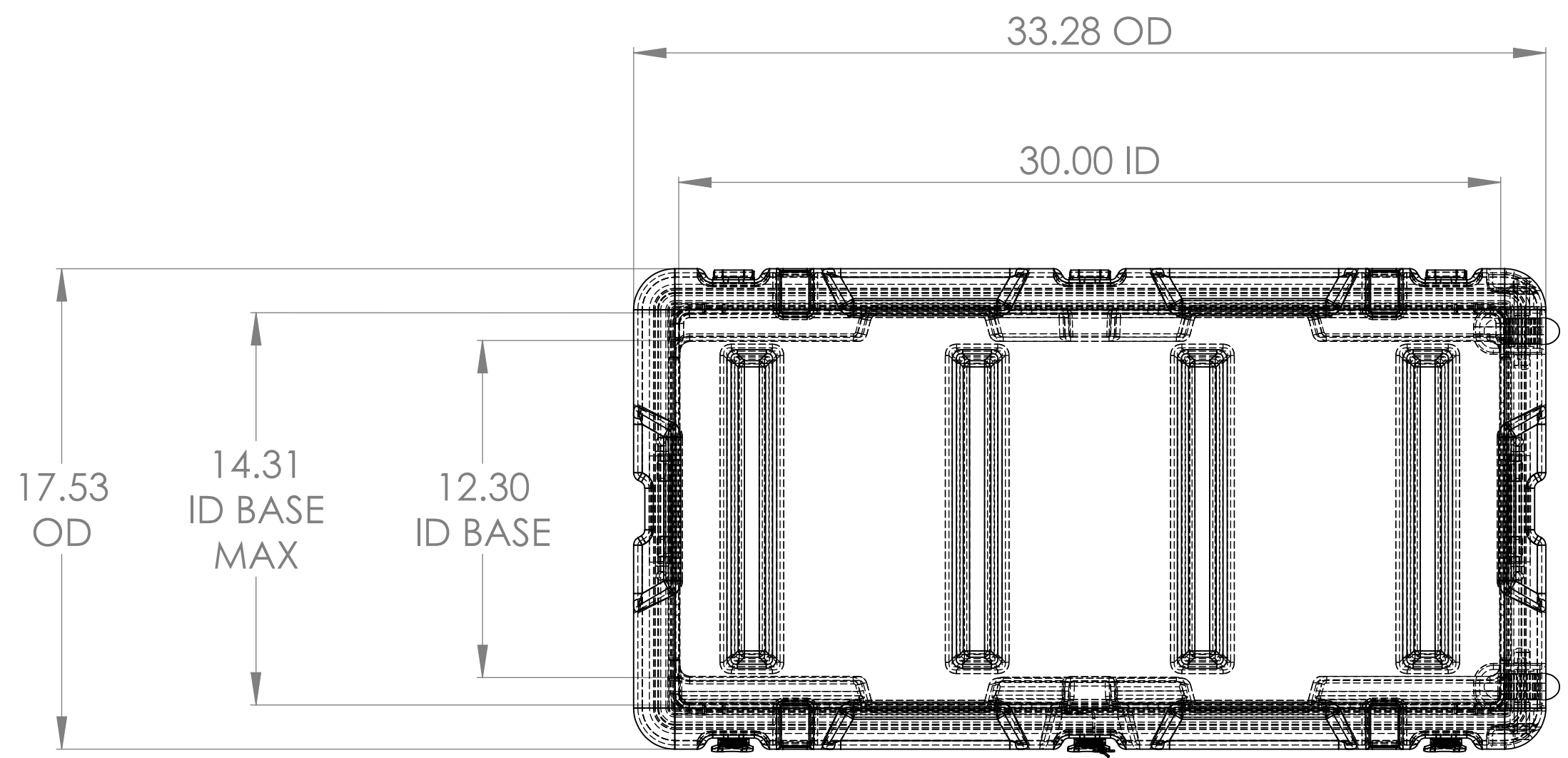

|                            |  |
|----------------------------|--|
| MATERIALS:                 |  |
| SEE SHEET 1                |  |
| ONE COMPLETE SET INCLUDES: |  |
| SEE SHEET 1                |  |

| DIMENSIONAL TOLERANCES                          |                             |
|---|-----------------------------|
| ALL DIMENSIONS IN INCHES UNLESS NOTED OTHERWISE |                             |
| 00 - 06"  | 0.020 + 0.005 * (DIMENSION) |
| 06 - 50"  | 0.030 + 0.005 * (DIMENSION) |
| 50 - 100"                                       | 0.030 + 0.006 * (DIMENSION) |
| ASSEMBLY:                                       |                             |
| SEE SHEET 1                                     |                             |

|          |           |          |
|----------|-----------|----------|
|          | NAME      | DATE     |
| DRAWN    | M SCHRAPP | 02/28/11 |
| CHECKED  | J THOMSON |          |
| APPROVED | J THOMSON |          |





TITLE:  
 AMERIPACK  
 AP3013-1303WH  
 DIMENSIONS

|      |               |     |
|------|---------------|-----|
| SIZE | DWG. NO.      | REV |
| C    | AP3013-1303WH | 1   |

SCALE: N/A SHEET 2 OF 3

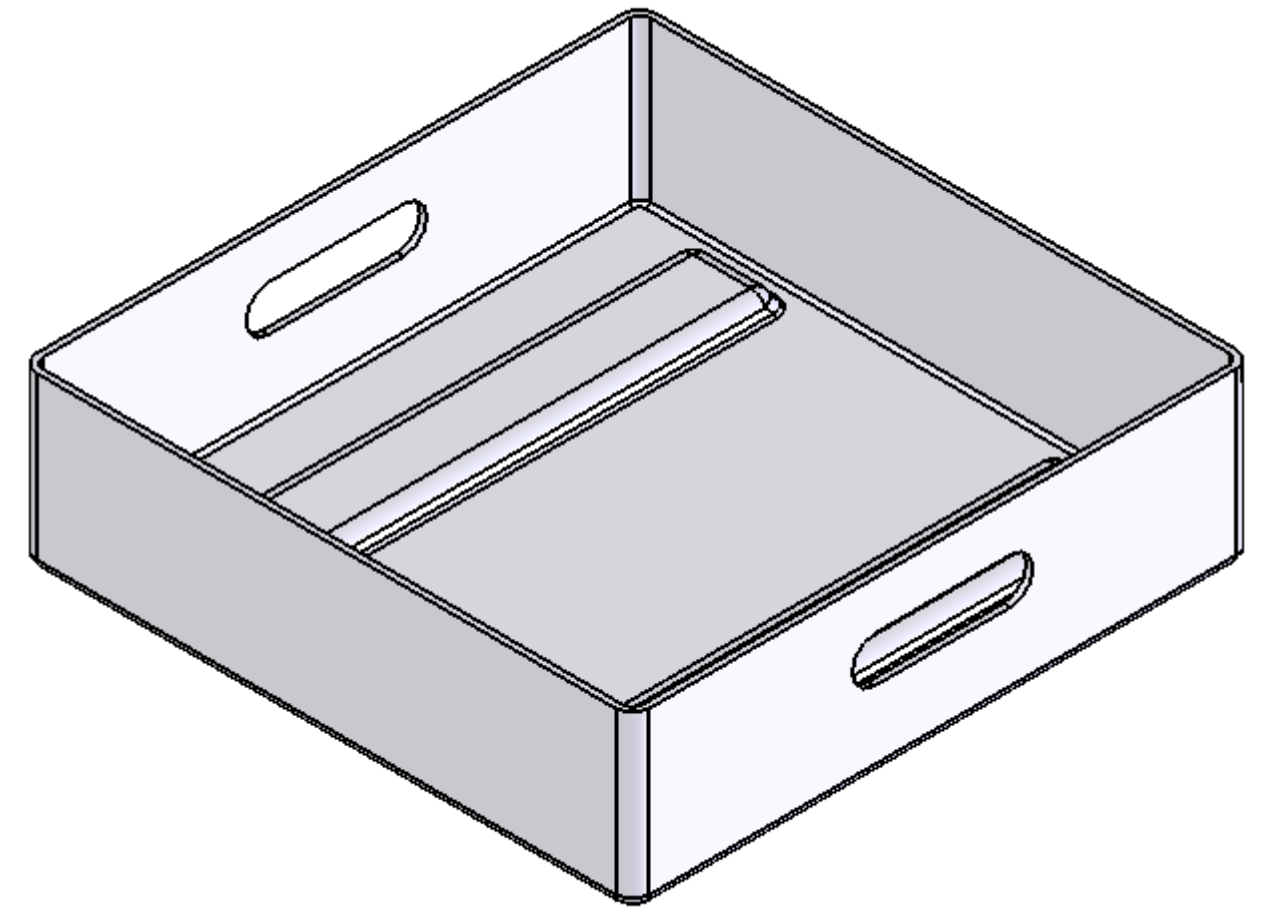
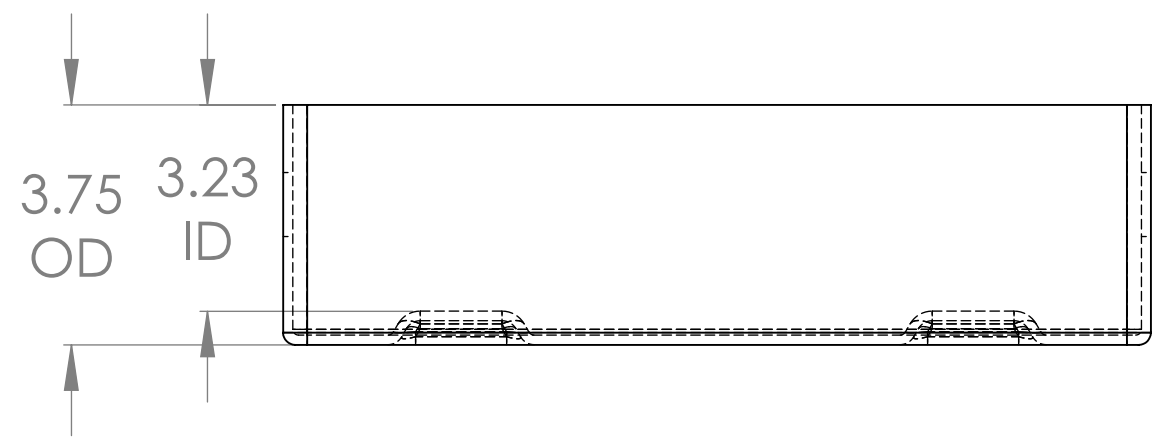
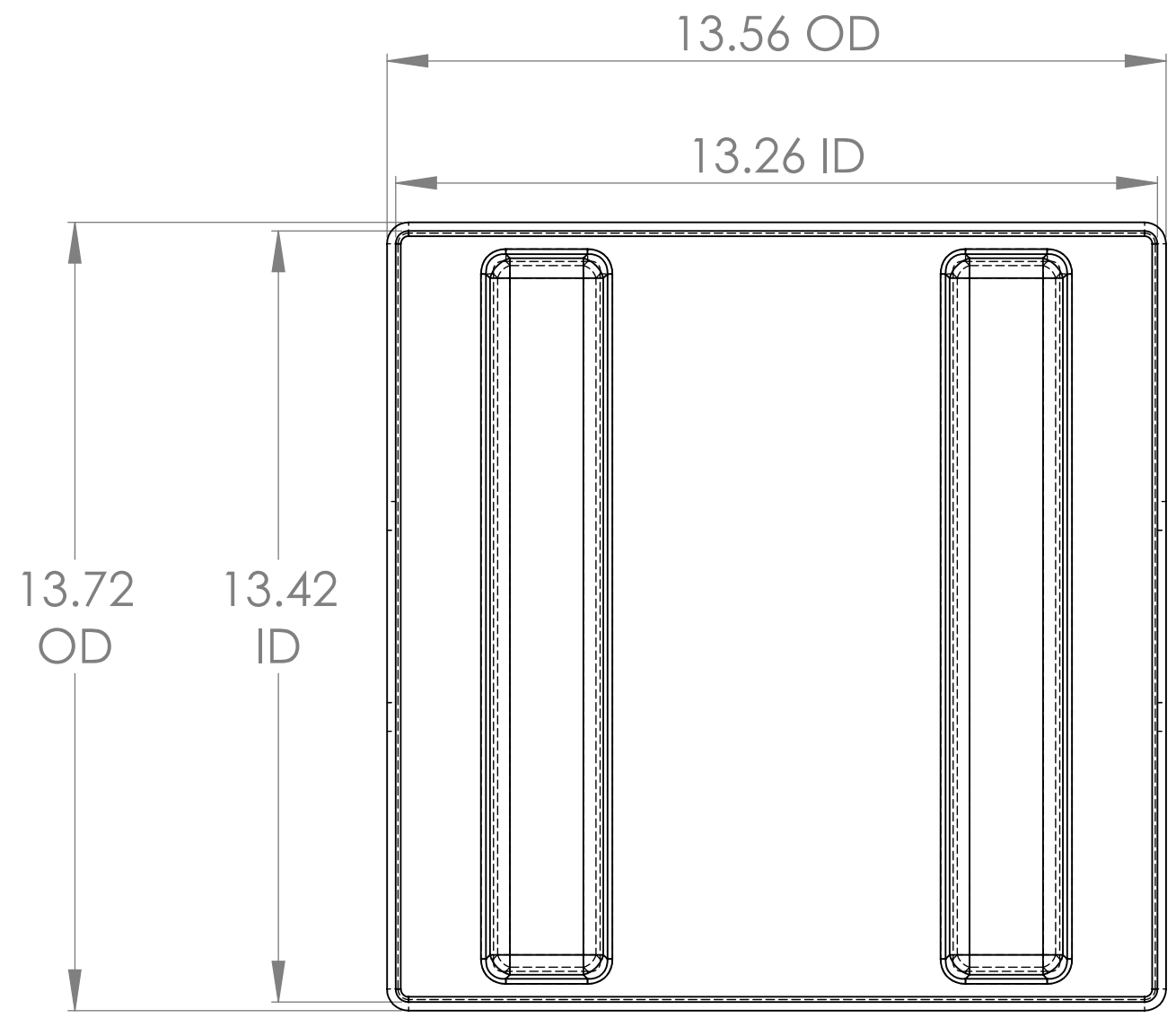
8 7 6 5 4 3 2 1



|                            |  |   |                 |  |                    |
|----------------------------|--|---|-----------------|--|--------------------|
| MATERIALS:                 |  | DIMENSIONAL TOLERANCES                          |                 |  |                    |
| SEE SHEET 1                |  | ALL DIMENSIONS IN INCHES UNLESS NOTED OTHERWISE |                 |  |                    |
|                            |  | 00 - 06"  | 0.020 + 0.005 * | (DIMENSION)  |                    |
|                            |  | 06 - 50"  | 0.030 + 0.005 * | (DIMENSION)  |                    |
|                            |  | 50 - 100"                                       | 0.030 + 0.006 * | (DIMENSION)  |                    |
| ONE COMPLETE SET INCLUDES: |  | ASSEMBLY:                                       |                 | NAME   | DATE               |
| SEE SHEET 1                |  | SEE SHEET 1                                     |                 | DRAWN  | M SCHRAPP 02/28/11 |
|                            |  |   |                 | CHECKED  | J THOMSON          |
|                            |  |   |                 | APPROVED   | J THOMSON          |
|                            |  |   |                 | <br>TITLE: AMERIPACK AP3013-1303WH REMOVABLE TRAY<br>SIZE   DWG. NO.   REV<br><b>C</b> AP3013-1303WH   1<br>SCALE: N/A   SHEET 3 OF 3 |                    |

**PROPRIETARY AND CONFIDENTIAL**  
 THE INFORMATION CONTAINED IN THIS DRAWING IS THE SOLE PROPERTY OF AMERIPACK. ANY REPRODUCTION IN PART OR AS A WHOLE WITHOUT THE WRITTEN PERMISSION OF AMERIPACK IS PROHIBITED.